

Donaldson® Cyclone Separators are designed for efficient removal of liquid water and particulate from compressed air and gases.

Donaldson DF-C Cyclone Separators deliver high separation efficiency at low pressure drop through an optimal flow-path design. An innovative insert in the cyclone head creates centrifugal action that forces liquid and particulate to the housing wall. Friction with the housing causes the liquid and particulate to lose part of their kinetic energy and drop out of the higher moving airstream. Collected condensate is removed by a time controlled UFZ condensate drain, while the purified compressed air or gas exits to the industrial application downstream.

Available in six different sizes with a flow range from 70 to 647 scfm at 100 psig. Conforms to European directive 97/23/EG for pressure vessels.

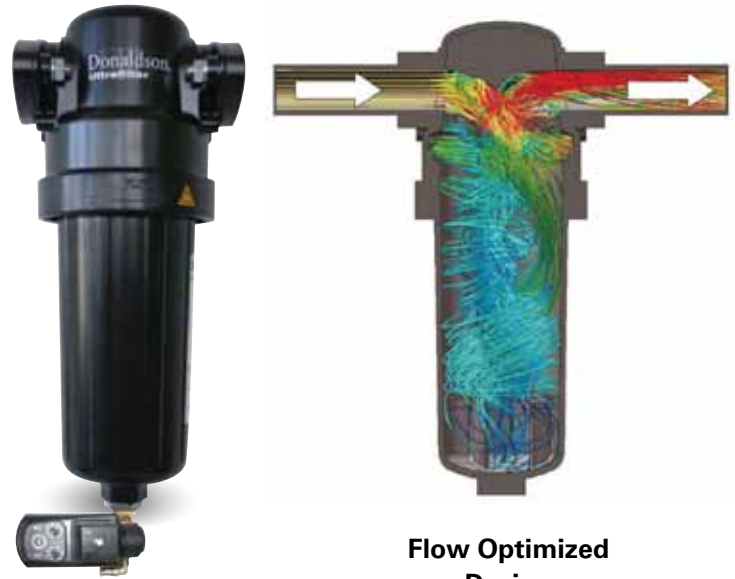

**DF-C Standard
with UFZ time controlled
condensate drain**

**Flow Optimized
Design**

FEATURES

FEATURES	BENEFITS
Flow-optimized design	Low pressure drop resulting in energy savings
Innovative spin insert	High efficiency over a broad flow range
Bayonet lock ensures housing cannot be opened under pressure	High safety during operation
Immersion-laquered housing on inside and outside surfaces	Long-term corrosion protection
Wall-bracket and UFM-T electronic level-controlled condensate drain options	Flexibility to meet installation and application requirements

DF-C CYCLONE SEPARATOR

SPECIFICATIONS

Materials	
Filter Housing	Aluminum die cast
Timer Drain	Brass
Sealings	Viton®*/NBR

Operating Conditions	
Maximum Operating Pressure	232 psi
Test Pressure	332 psi
Continuous Operating Temperature	34°F to 149°F

Retention Rate Related to 116 psia	
≥ 5 micron	99%
≥ 10 micron	100%

Classification per 97/23/EG for Fluids Group 2	
DF-C 0120 to DF-C 0320	Art. 3, Par. 3
DF-C 0450 to DF-C 1100	Cat. 1

DF-C Cyclone Separator
Differential pressure related to nominal flow rate

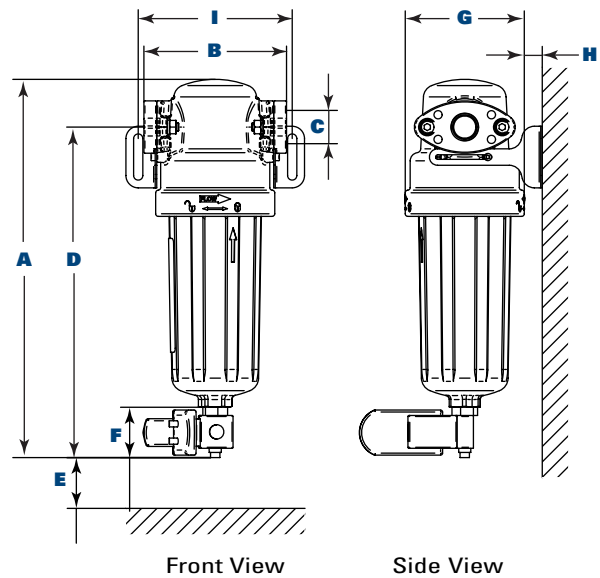
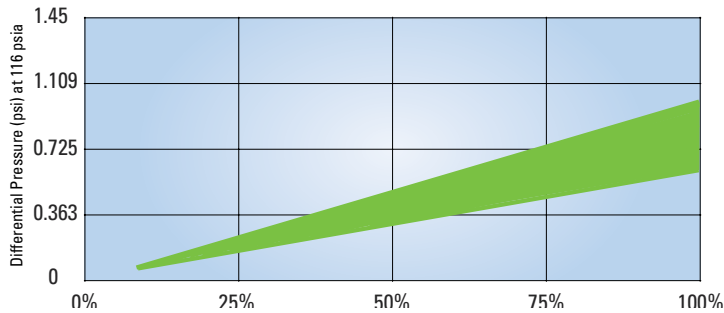

Size	Flow Rate** (scfm)	Volume (gal)	Weight (lbs)	Dimensions (inches)								
				A	B	C (in FNPT)	D	E	F	øG	H (min/max)	I
0120	70	0.106	3.5	11.14	4.06	½	9.6	4.53	1.93	3.35	0.88 / 2	4.2
0210	123	0.304	5.9	14.51	5.5	¾	12.7	7.1	1.93	4.6	0.88 / 2.8	5.9
0320	188	0.304	5.9	14.51	5.5	1	12.7	7.1	1.93	4.6	0.88 / 2.8	5.9
0450	264	1.32	6.4	22.5	7.5	1½	20	9.8	1.93	6.3	0.88 / 13.56	7.5
0750	441	1.32	6.4	22.5	7.5	2	20	9.8	1.93	6.3	0.88 / 13.56	7.5
1100	647	1.32	6.4	22.5	7.5	2	20	9.8	1.93	6.3	0.88 / 13.56	7.5

* Viton® is a registered trademark of DuPont Performance Elastomers L.L.C.

** Nominal flow at 100 psig, scfm related to 14.7 psia.



Donaldson Company, Inc.
Compressed Air and Process Filtration
PO Box 1299
Minneapolis, MN
55440-1299 U.S.A.

Tel 800-543-3634 (USA)
Tel 800-343-3639 (within Mexico)
Fax 952-885-4791
compressedair@donaldson.com
donaldson.com